

Operating Weight: 49500 kg Bucket Capacity: 2.5 - 3.1 m³ Engine Power: 403 HP (300 KW)/ 1800 rpm



**EXCELLENT PERFORMANCE
HIGH RELIABILITY
EASE OF SERVICEABILITY**

SANY HEAVY INDUSTRY INDIA PVT. LTD.

HEAD OFFICE
 Address : Plot No. E-4, Chakan Industrial Area Phase-III,
 Village Kuruli, Taluka Khed, District Pune - 410501,
 Maharashtra, INDIA.
 Tel : +91 21 35670288, Fax: +91 21 35670300
 E-mail : customercare@sany.in
 Website : www.sany.in
Toll Free No.: 1800-209-3337



Material & specification are subject to change without prior notice in accordance with our continuous technical innovations. Featured machines in photos may include additional equipment.



**SERIES 9
SY500LC
HYDRAULIC EXCAVATOR**

The C-9 series of excavators developed by SANY adopts major breakthroughs ranging from power system to control system for high efficiency and energy savings. This, in addition to insistence on 'Quality-In-Everything-We-Do', has delivered the world-class excavators best suited for the multitude of your work requirements with superior advantages of uninterrupted operations, unmatched productivity at better fuel economy, helping you make more profits.



EXCELLENT PERFORMANCE

SY500LC-9H excavator is built with well-renowned Isuzu engine and superior synchronization with advanced hydraulic system offering best balance of performance demands and fuel economy to suit job requirements and application.



HIGH RELIABILITY

Sany design and manufacturing capabilities have resulted into durability with improved life of components and longer service life.



BEST IN CLASS OPERATOR COMFORT

The machine is featured with comfortable seating arrangement, optimized cabin space, wider visibility, safety grills and easy access to switches. Overall, the new cabin provides comfortable and safe environment for the operator.



EASE OF SERVICEABILITY

With superior attention to details, smart provisions are made for easy serviceability and simplified maintenance that results into improved uptime.



REMOTE MONITORING SYSTEM

Remote monitoring system, called EVI, installed in the machines helps in tracking various working parameters. This information can be used for improving site efficiency, maximizing operating performance while reducing maintenance costs.



EXCELLENT PERFORMANCE

SANY SY500LC-9H excavator is designed for excellent performance with combination of best in class productivity and superior fuel economy.

UNMATCHED PRODUCTIVITY

POWERFUL ENGINE

SY500LC-9H is powered by well renowned Isuzu engine with exceptional work capacity and optimize fuel economy for moving heavy material quickly and efficiently.

ADVANCED HYDRAULIC SYSTEM

When the machine deals with an operating requirement of moving heavy material quickly and efficiently, it needs the best hydraulic power that SY500LC-9H offers.

The advance control valve which has been thoroughly optimized provides excellent performance in combined operations.

Hydraulic valves ensure that oil flow is available at the point of priority as per required flow. This results in the best available power with optimum fuel consumption.

During boom lowering & arm opening operation, regeneration feature results into faster movement by routing oil through regeneration valve. It prevents cavitation and enhances cylinder performance. This reduces friction losses, pressure drops ensuring more power to the ground for heavy duty applications.

SUPERIOR FUEL EFFICIENCY

DYNAMIC OPTIMIZATION MATCHING CONTROL SYSTEM (DOMCS)

DOMCS ensures quick response to the change of operating variables in order to achieve optimum engine performance as per the external load demand facilitating the optimum control of excavator external load operation system.

WORK MODES AND AUTO-IDLE

SY500LC-9H is equipped with four working modes (P, H, S, I) to match engine speed, pump speed and system pressure with versatile work application. Automatic idle function reduces fuel consumption significantly leading to reduced operating cost.

SUPERIOR COOLING EFFICIENCY

Independent oil cooling system adjusts fan speed according to hydraulic oil temperature to meet cooling needs of harsh mining conditions, thereby improving over all cooling efficiency.

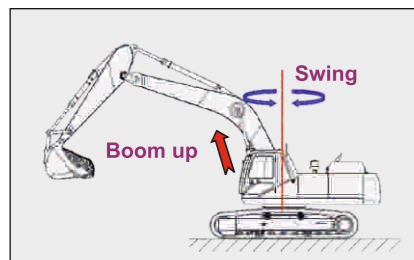

Boom Priority System

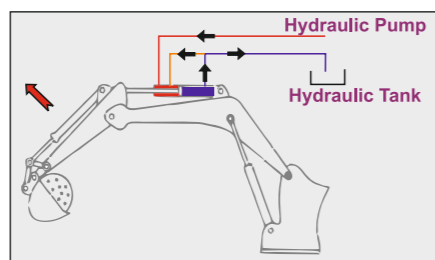

Regeneration System

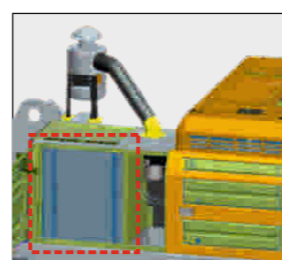

Independent Oil Cooler

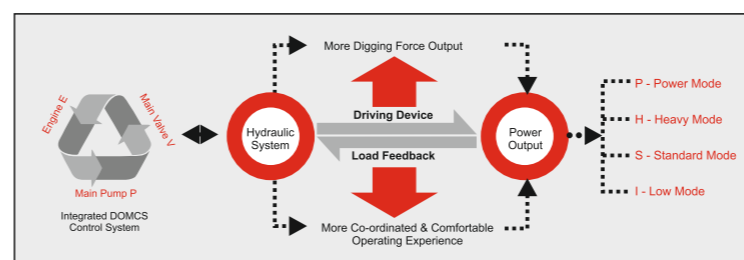

DOMCS Control System

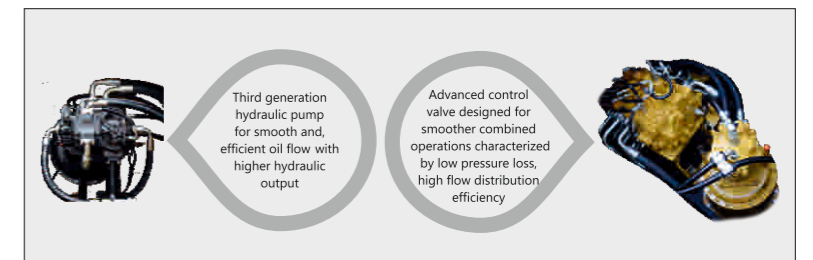

Hydraulics



HIGH RELIABILITY

The boom and arm is made of large box-type structure welded with high strength steel sheet. Welded plates for excellent torsional resistance inside the structure leads to unmatched durability that prevents deformation under harsh conditions.

ROBUST STRUCTURE

REINFORCED BOOM

Robotically welded, heavy-duty boom is designed for best distribution of load throughout the boom structure which reduces lateral stress by 10% during the boom swing.

REINFORCED ARM

Arm's rear support is specially reinforced offering excellent torsional resistance imparting greater strength to the arm assembly for longer lifetime.

WEAR RESISTANT BUCKET

High strength bucket surface gives longer service life. Optimized design helps in reducing rock and sand resistance in turn decreases wear of the bucket body while digging.

HIGH STRENGTH UPPER FRAME

Heavy duty upper frame is designed to improve bending strength of the platform. D-shaped large section stronger beam can withstand external shocks.

ENHANCED UNDERCARRIAGE

Undercarriage is made up of high strength alloy steel with good wear resistance and durability.

X-TYPE FRAME AND BOX TYPE STRUCTURE

It has high strength and stiffness with excellent torsional and bending resistance. Reinforcing plate has been added to improve the strength of the lower frame. This improves working life.

STRENGTHENED TRACK

Anti-collision ribs have been added to improve its capacity of anti-deformation and protect the guide pulley.

Increased size of oil chamber of Idler improve performance of floating seal results into effective life.

Strengthened undercarriage is featured with full length track guard for better protection in hardest possible application.



Boom & Arm

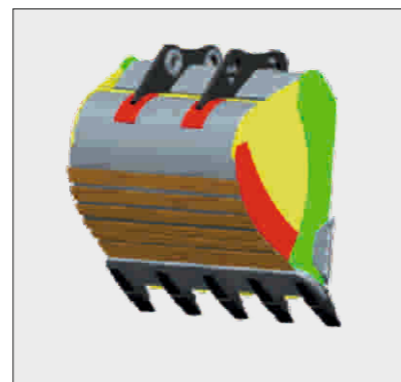

Bucket



X-Type Frame



Undercarriage



BEST IN CLASS OPERATOR COMFORT

Newly designed spacious air conditioned cabin is equipped with weight indication adjustable suspension seat. Height, backrest inclination, armrest height, rear cushioning of the seat is designed for operator comfort. This reduces operator fatigue and enhances working efficiency.

COMFORT

MULTI-DUCT AIR CONDITIONING SYSTEM

The standard large capacity air conditioner keeps in-cab air fresh by purification & recirculation which reduces operator fatigue.

ADVANCE SILICON RUBBER SHOCK ABSORBERS

Cabin bearing is attached to upper frame with silicone viscous shock absorber which effectively dampens vibrations while enhancing operator comfort.

PRESSURIZED HERMETIC CABIN

Cabin is air tight sealed and is dust free. It prevents dust entry into cabin gadgets by maintaining pressure variation between cabin and outside atmosphere.

ERGONOMICALLY DESIGNED JOYSTICK

Control levers and joysticks control are smartly designed for horizontal and vertical stroke of joystick for low lever effort.

HIGH STRENGTH ROOF TOP

The top plate of cabin is punch-formed with thick high-strength steel sheet integrated with reinforced ribs which offers excellent deformation-resistance resulting into operator safety in tough environments.

CLEAR VISIBILITY

Larger windows of the newly-designed spacious cabin provide you with a wider view. The operator can clearly see the work equipment condition and the surrounding through the front, side and back windows.

SAFETY HEAT SHIELD AND FAN COVER

Turbocharger and engine radiator are insulated with heat resistant cover. Engine radiator fan is fully enclosed with wire-mesh to reduce risk of accidents.

OTHER SAFETY PROVISIONS

Operator's cabin is equipped with safety hammer, fire extinguisher, seat belt, protective fence, hydraulic pilot lock.



AC Duct



Shock Absorber



Seat Adjustment



Joystick



Cabin Roof Top

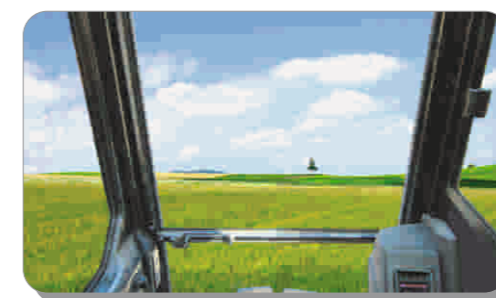

Visibility



Fan Cover



Safety Hammer



EASE OF SERVICEABILITY

The use of OEM parts and quality elements effectively extends the service life and maintenance intervals. The time for maintenance is also reduced. Remote installation of replacement parts gives easy maintenance, higher utility and lower service cost.

EASY ACCESS

FILTER REPLACEMENT COMFORT

Access to the various filters (engine filter, pilot filter and A.C. filter) is very easy being mounted in hydraulic pump compartment for making cleaning easier.

OIL BATH PRE CLEANER

In dusty environments, It prevents dirt from entering and damaging the engine thereby improving reliability of engine and reduces associated maintenance cost.

EASY CLEANING FOR RADIATOR

Radiator and oil cooler packing is easily washable which leads into excellent cooling capacity and ensures prolonged engine running without being overheated.

FUEL FEED PUMP

Fuel feeding pump is provided for easy fuel refilling.

EASE OF REGULAR CHECK UP

Regular performing components (swing gear greasing, engine oil and hydraulic oil) of the machine can be easily checked up which leads to time saving and long working ability.

LARGE LCD COLOR DISPLAY

Cabin is equipped with waterproof, dust proof and vibration proof anti-interference colour LCD display which provides real-time information regarding machine working status, abnormal alarm function etc. ensuring safe operation.

IMPROVED GREASING

Graphite infused bushes are provided for prolonged greasing interval. Centralized greasing points are provided for easy greasing of various points of boom assembly.

FLOATING BUSH PROVISION

Floating bush and shim arrangement are provided in bucket for easy and quick adjustment.



Air Filter



Oil Bath Pre Cleaner



Radiator



Fuel Filter



Fuel Feed Pump



Engine Oil Level Check-up Access



Color Monitor



Graphite Bush

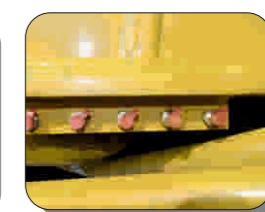

Centralized Greasing Points

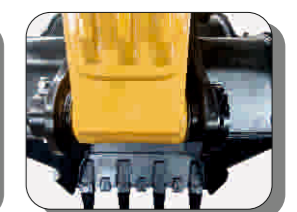

Floating Bush Provision



EVI REMOTE MONITORING

EVI in SANY C-9 series excavators is a sophisticated system that helps you to remotely monitor wide range of excavator functions and access operating information.

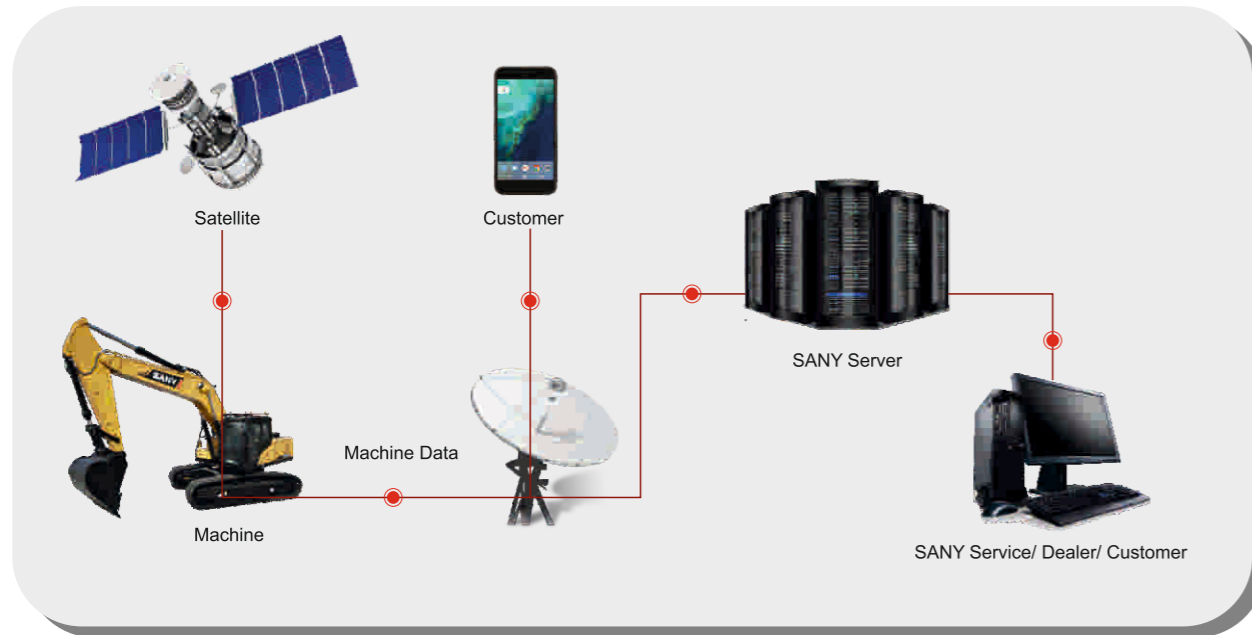

By 05-02-2016 08:43:58, the machine [15SEY008105571] Total working hour is: 592.35 This time working hour is: 0.00 Longitude is: 0, Latitude is: 0, Gear position is: 0, Engine speed is: 0, Fuel level: 52.5322; [SanyEVI]

By 05-02-2016 09:15:47, the machine [15SEY008104671] Total working hour is: 395.45 This time working hour is: 0.02 Address: Kamakhyanagar Dhenkanal Road, Mahulapal, Odisha 759018, India, Gear position is: 0, Engine speed is: 22.4524; Fuel level: 75.30232; [SanyEVI]

Daily SMS updates

1. Hour Meter Reading
2. Machine run on that particular day
3. Location of the machine
4. Engine speed & Gear Position
5. Fuel Level



MACHINE OPERATING MANAGEMENT

Daily machine operation hours, non-working hours, engine idling time can be monitored and remaining fuel in the diesel tank can be determined.

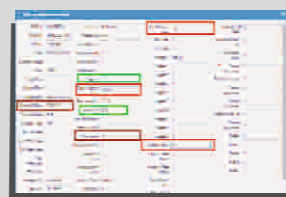

REAL-TIME MONITORING

The real-time monitoring system displays various operating parameters like hydraulic oil pressure, engine rpm, working mode along with selected gear, coolant temperature, voltages and current etc.



LOCATION & TRACKING

Machine's current location can be captured for easy tracking. Route to working site of the machine can be determined as well.

TECHNICAL SPECIFICATIONS

ENGINE	
Model	ISUZU CWG1X
Type	6 Cylinder, Inline, Water Cooled
Rated Engine Power	403 HP(300KW)/1800 rpm
Max. Torque	1950 N.m
Displacement	1568 L

CONTROL SYSTEM	
Control System	DOMCS Intelligent Controller
Working Modes	P, H, S, I
Remote Monitoring System	GPRS, GPS, GIS

HYDRAULIC SYSTEM	
Main Pumps	2 Variable Displacement Axial Piston Pumps
Max. Flow	2 X 366 lpm
Pilot Pump	Gear Pump
Travel Motor	2 Axial Piston Motor with Parking Brake
Swing Motor	Axial Piston Motor with Swing Holding Brake

RELIEF VALVE SETTINGS	
Implement Circuit	34.3 Mpa
Swing Circuit	26.9 Mpa
Travel Circuit	31.4 Mpa
Pilot Circuit	3.9 Mpa

UNDERCARRIAGE & WORKING DEVICE	
Track Shoes (Each side)	50
Upper Rollers (Each side)	2
Lower Rollers (Each side)	9
Std. Track	600 mm
Std. Boom	6550 mm
Std. Arm	2500 mm
Std. Bucket	3.1 m ³ GP Std.

PERFORMANCE	
Max. Travel Speed(High/Low)	5.4/3.1 km/h
Swing Speed	8.0rpm
Grade ability	70%/35°
Ground Pressure	87.1 kPa
Max. Tracking Force	339 kN
Bucket Digging Force	280 kN
Arm Digging Force	248 kN

SERVICE REFILL CAPACITIES	
Hydraulic Tank	480 L
Fuel Tank	680 L
Engine Oil	50 L
Radiator	24 L
Swing Device	14 L
Travel Device	2x15 L

CAB	
AC	Std.
Cabin Guard	Opt.

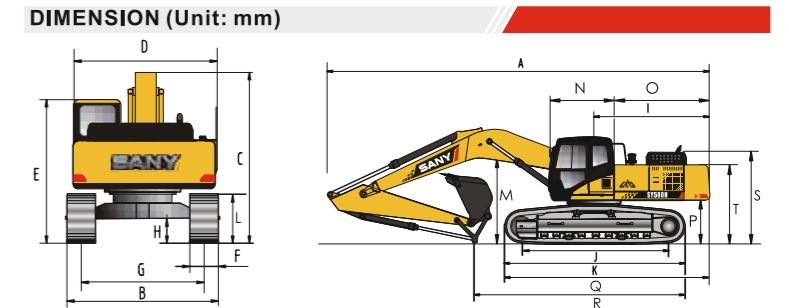

DIMENSION (Unit: mm)		Arm 2500
A. Overall Length		11700
B. Overall Width		3360
C. Overall Height		3980
D. Upper Width		3290
E. Overall Height of Cab		3470
F. Std. Track Shoe Width		600
G. Track Gauge		2740
H. Min. Ground Clearance		560
I. Rear-end Swing Radius		3765
J. Distance between Tumbles		4415
K. Under Carriage Length		5440

WORKING RANGE

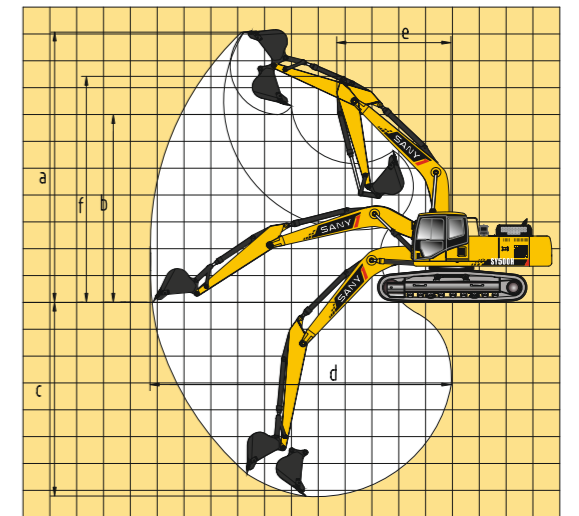

WORKING RANGE (Unit: mm)		Arm 2500
a. Max. Cutting Height		10120
b. Max. Dumping Height		6700
c. Max. Digging Depth		6600
d. Max. Digging Reach		10850
e. Min. Swing Radius		5130
f. Max. Height at Min. Swing Radius		8800

BUCKET				
Capacity	Width (mm)	Weight (kg)	Tooth Point	Arm Length
3.1m ³ GP Std.	1910	2780	5	✓
2.5m ³ HD Opt.	1730	2460	5	✓

LIFTING CAPACITY

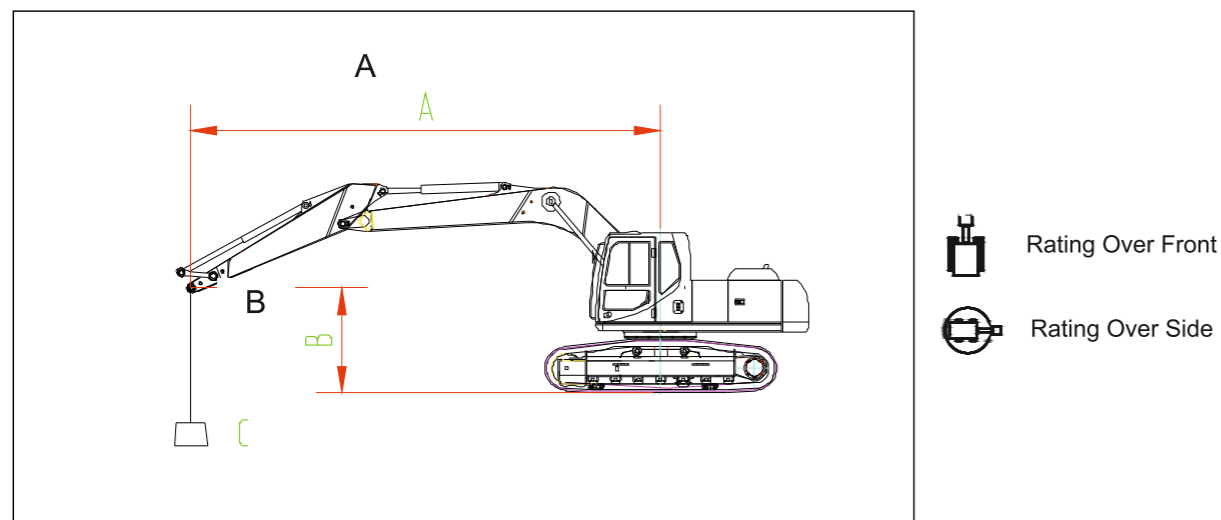

A \ B	7.5m		6.0m		4.5m		3.0m	
	Rating Over Front	Rating Over Side	Rating Over Front	Rating Over Side	Rating Over Front	Rating Over Side	Rating Over Front	Rating Over Side
6.0m kg	10106*	10106*	10912*	10912*				
4.5m kg	10756*	10756*	12455*	12455*	16299*	16299*		
3.0m kg	11633*	10333	14199*	14199*				
1.5m kg	12423*	9992	15561*	13530				
0m kg	12865*	9782	15204*	13216	21861*	20272		
-1.5m kg	12688*	9752		13161	21027*	21027*	18776*	18776*
-3.0m kg			14822*	13352	19179*	19179*	25040*	25040*

Remarks:

- 1.Rated figure meets the criterion of GB/T 13331-2005/ISO 10576
- 2.Rated rollover loading is 75% of static rollover loading, rated limiting hydraulic weight is 87% of limiting hydraulic weight.
- 3.Loading radius is the distance from the loading point to the swing center.
- 4.The figure with *stands for the rated figure of the limiting hydraulic weight.

STANDARD EQUIPMENT

ENGINE

- Mode control (P, H, S and I) Start motor 24V/7.5KW
- Alternator 70A
- Air pre-cleaner
- Oil bath air filter
- Cylindrical engine oil filter
- Cylindrical fuel filter
- Engine oil cooler
- Separate water scattered
- Fan windshield
- Separately installed engine
- Automatic deceleration system
- Accelerating system

UNDERCARRIAGE

- X type frame
- Travel motor guard
- Hydraulic track tensioner
- Fully protective track guard
- Carrier roller and track roller
- Reinforced track link with pin and seal
- 600 mm track shoes

SWING PLATFORM

- Fuel level float
- Hydraulic oil level gauge
- Toolbox
- Rear view mirror (R)
- Swing brake
- Reinforced side pedal Bottom cover plate
- Mine side beams
- Bottom cover
- Fuel break switch

AIR CONDITIONING SYSTEM

- Air conditioner (imported)
- Air conditioner control panel
- Fresh air system

HYDRAULIC SYSTEM

- Working mode selection switch
- Power enhancement device
- Control valve with main relief valve
- Spare oil port for control valve
- Strainer
- Return oil filter
- Pilot filter

FRONT WORK EQUIPMENT

- Flange pin
- Bucket clearance adjustment
- Central lubrication system
- Dust ring-seal of bucket pin
- Fully-welded box boom
- Fully-welded box arm
- Guard
- Standard bucket

ALARM LIGHTS

- Oil pressure alarm
- Engine overheating alarm
- Fuel oil alarm

LAMP & CIRCUITE SWITCH

- Boom working lights
- Platform pedal lights
- Top of cab lights
- Emergency stop switch

OPERATOR STATION

- Noise proof steel-structured cab
- Toughened light-color window
- 4 silicone rubber damping support
- Operable roof hatch, upper front window and left window
- Rear window,alternate exit
- Silent window wiper with washer
- Adjustable inclined seat with adjustable armrest
- AM-FM radio with digital clock
- Foot rest and floor mat
- Loudspeaker,rear view mirror
- Seat belt and fire extinguisher
- Cub holder and cab light
- Ashtray alternate hammer
- Storage box, literature bag
- Hydraulic lockout control
- Fully automatic air-conditioner
- Wiper with washer

OTHERS

- Standard battery
- Lockup engine hood
- Lockup fuel filler cap
- Anti-skid film, handhold and passage
- Travel direction mark
- Hand grease gun
- Electric diesel pump